

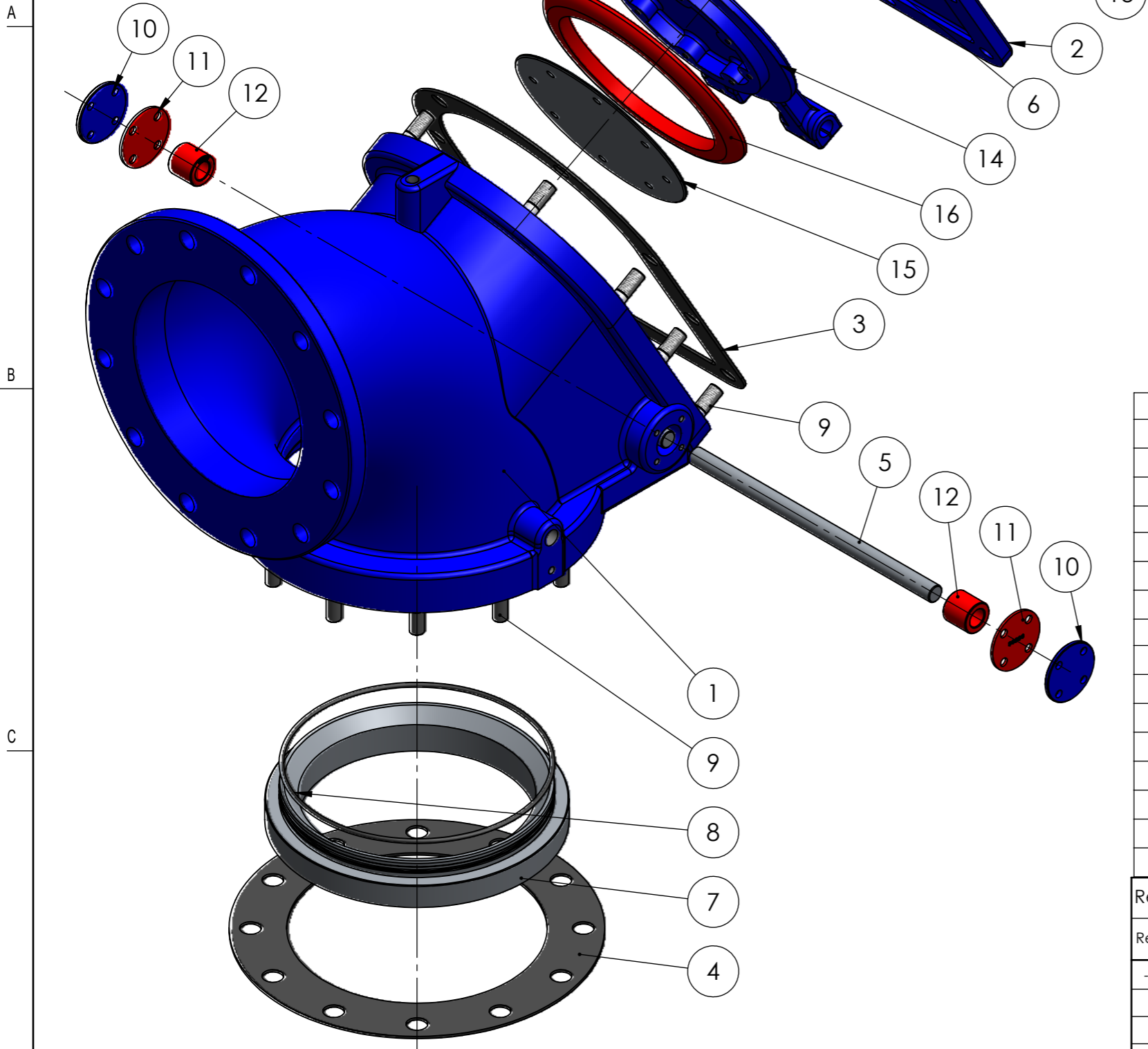

# NRV 250-10 SPAREPARTS



ITEM NO.	PART NUMBER	DESCRIPTION	QTY.
1	33274	Flap Valve 250-10 Inch	1
2	33283	Cover Flap Valve 250-10 Inch	1
3	33282	Gasket Cover Flap Valve 250-10 Inch	1
4	33278	Gasket DN250 10 Inch	1
5	33276	Flap Valve Shaft 250-10 Inch	2
6	33275	Stop Damper Flap Valve 250-10 Inch	1
7	33279	Flap Valve Seat 250-10 Inch	1
8	33340	O-RING 280 mm x 5 mm	1
9	30834	Stud Bolt M16 x 55-30-15	21
10	30828	Bearing Cover Flap Valve 200-8 inch	2
11	30830	Gasket Bearing Cover Flap Valve 200-8 inch	2
12	30829	Bearing Bush Flap Valve PU 200-8 inch	2
13	30832	Handle Flap Valve Cover 200-8 inch	1
14	33277	Flap Valve 250-10 Inch With 8 Holes	1
15	33281	Flap Valve Seal SS-Plate 250-10 Inch	1
16	33280	Flap Valve PU-Seal 250-10 Inch	1

Revision information				UNSPECIFIED GEOMETRICAL, LINEAR AND ANGULAR TOLERANCE SHALL CONFORM TO ISO 2768-MK (UNLESS OTHERWISE STATED)		format	scale	projection	 Dewatering Technologies
Rev	Date	Drn	Appr	Info		A3	1:5.5		
-	10-05-2023	JG	-			Drawn:	JG	web:	www.impulsebv.com
						Date:	10-05-2023	Material:	
						Rev.:	-	Weight:	Material <not specified> Kg
						State:	Approved	Treatm.:	Assemble

PDM No. : 33645 Title: FLAP VALVE 250-10 INCH EXPLODED VIEW

All rights strictly reserved. Reproduction or issue to third parties in any form  
 whatever is not permitted without written authority from the proprietor.  
 Property of Impulse Holding B.V. Copyright Impulse Pumps B.V.